

# Cascade G2

Retractable, Above Ceiling Screen System

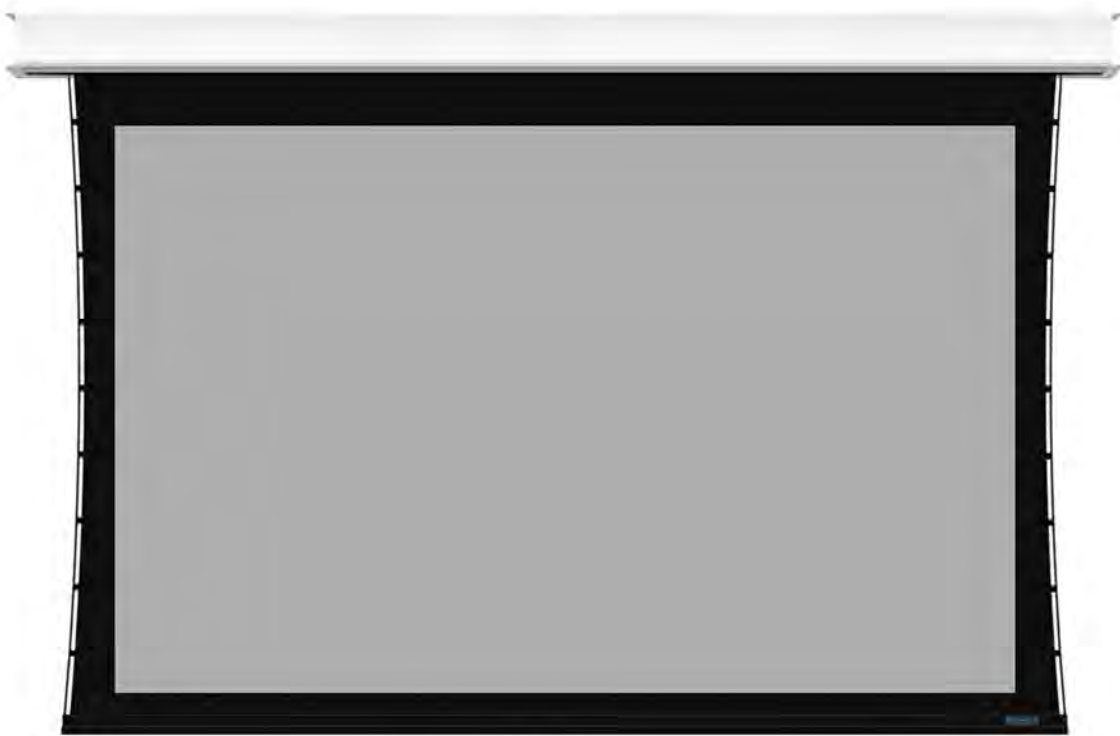

Printed in U.S.A. ©2025 Stewart Filmscreen Corporation

Stewart Filmscreen reserves the right to make changes to the product specified in this document. Sizes and specifications subject to change without notice at Manufacturer's discretion. From time to time, this document is updated. Current versions of documentation are posted on the Stewart Filmscreen website at:

**[www.stewartfilmscreen.com](http://www.stewartfilmscreen.com)**

# Cascade G2

## OWNERS MANUAL

### Contents

To the Owner . . . . .	4
About Cascade G2 . . . . .	5
Preparing the Installation . . . . .	6
Ceiling Mount. . . . .	9
Threaded Rod Mount. . . . .	11
Wing-Out Mount. . . . .	13
Fascia End Pieces and Dust Cover Installation . . . . .	15
Electrical . . . . .	16
Intelligent Motor Control (IMC) (Standard) . . . . .	17
IMC Wiring with Decora Wall Switch (Standard). . . . .	18
12 Volt Projector Trigger (Standard). . . . .	19
Decora Paddle Wall Switch (Standard) . . . . .	20
Three Button Wall Switch (If Equipped). . . . .	21
IMC with IR Receiver and Remote (IF Equipped). . . . .	22
IR Wall Switch and Remote (If Equipped). . . . .	23
Operating the Screen. . . . .	24
Adjusting the Screen Limit Switch . . . . .	25
Caring for and Cleaning the Screen . . . . .	27
Troubleshooting . . . . .	28
Warranty . . . . .	30

## TO THE OWNER

---

Congratulations on purchasing the finest optical viewing screen in the world.

Your handcrafted Cascade G2 projection screen has been carefully inspected to ensure your optimal viewing experience will last for many years. Please take a moment to review this manual. It will guide you through the installation and the operation of your screen and will also provide you with detailed instructions on how to care for your screen's viewing surface.

From all of us at Stewart Filmscreen, we would like to thank you for choosing Cascade G2. Should you have any questions, please don't hesitate to contact our customer service department at 1 (310) 784-5300, or toll free at 1 (800) 762-4999. We're here to help.

### **ABOUT YOUR CASCADE G2 SCREEN**

The Cascade G2 is designed for ease of installation. The Cascade G2 features a self-finishing face-plate. There are no user-servicable parts contained within the unit.

# ABOUT CASCADE G2

---

The next generation Cascade offers a premium self-finishing above ceiling viewing experience. Newly designed, removable end flanges, makes the Cascade G2 easier to install than ever before. With a winning combination of your choice of both control and mounting options, and with Stewart's world-renowned premium screen materials, this screen is one of our most popular selling, above ceiling screens.

**NOTE:**

This owner's manual may describe options and features not equipped to the specific screen you have purchased.

**IMPORTANT SAFETY INFORMATION**

- Carefully read the instructions
- This screen can be installed by qualified audio video technicians
  - An electrician should be consulted when hardwiring the unit to a ceiling j-box
- For supply connections, use wires rated for at least 75 C
- Use copper or aluminum conductors
- For indoor use only
- Do not connect low voltage to line voltage power
- Earth ground terminal connection must be made as shown in wiring diagrams
- Proper short circuit and overload protection must be provided at the circuit breaker distribution panel. You may use up to a 20 amp maximum circuit breaker with adequate short circuit breaking capacity for your installation

**USING THIS MANUAL FOR INSTALLATION**

If you are using this manual to install the Cascade screen, you should be aware that it describes procedures for three types of mounting options. You must refer to the section for the type of mounting option you are utilizing.

For the instructions related to your specific mounting, refer to the appropriate page:

- Ceiling Mount (Page 9)
- Threaded Rod Mount (Page 11)
- Wing-Out Mount (Page 13)

For the instructions related to your specific controls, refer to the appropriate page:

- Intelligent Motor Control (IMC) (Page 17)
- 12 volt projector trigger (Page 19)
- Decora Paddle Wall Switch (Page 20)
- Three Button Wall Switch (Page 21)
- IR receiver and remote (Page 22)

# PREPARING THE INSTALLATION

---

Before proceeding with the installation of this screen, take time to thoroughly read and understand these installation instructions. **Failure to comply with the instructions contained in this manual may result in voiding your warranty.**

## SPECIFICATIONS

Specifications regarding the individual screen dimensions, weight, etc., are provided by the factory when the unit is ordered.

Before beginning the installation

Check the size and weight of the screen to be installed so that you can plan for the number of people required for installation.

You will need at least two people to mount a small screen. More are needed for larger, heavier screens.

Read everything before you do anything!

## What's inside the box?

- Inside your Cascade G2 unit box, you will find everything needed to get started enjoying your Stewart screen:
- Cascade G2 unit preassembled and prewired
- Cascade G2 end flanges and access panels
- Two mounts, specific to your order
- Packing material
- IR remote and IR receiver (standard control)
- Two RJ45 male connectors and two 3.5 mm trigger male connectors
- Cascade Quick Start Guide

## You will need

- A level
- A drill
- A drop cloth
- Tools for tightening fasteners
- Ladders for the personnel supporting the screen during the mounting process
- Fasteners appropriate for the surface on which the screen is being mounted

## PREPARING THE INSTALLATION (CONTINUED)

**Note:** Bolts and other fasteners for the screen are standard gauges and are sizes that are used in the U.S., regardless of the installation country. For this reason, sizes are expressed in inches rather than metric measurements.

### ⚠ CAUTION

Do not stand on the screen case or store it on its end. This will cause screen damage. If you are not going to install the screen immediately, make sure it remains horizontal during storage. **Note: Failure to comply with the instructions and guidance contained in this manual may result in voiding your warranty.**

### Unpacking

Be sure to unpack carefully in a clean area. Use special care when handling the screen so that it does not become soiled or damaged. If you plan to repack your screen and hardware for transportation to another location, you may want to photograph or make a note of how it was packed. Retain the packing material for future use, if desired.

**The Cascade screen has a special wrap retaining the batten to the case. This wrap may be left in place until after the screen has been mounted. The wrap consists of a foam piece attached to the batten and wrapped behind the case with tape (see Figure 1).**

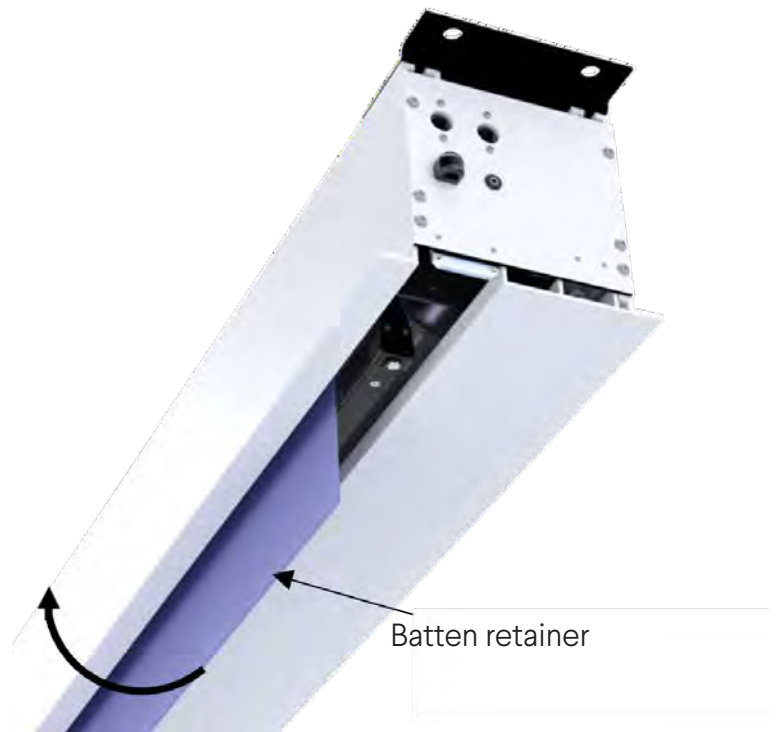

Figure 1. Cascade bottom view with batten retainer installed

**IMPORTANT:** Cascade ships without the end flange and access panel attached to the case. These two pieces need to be installed after installation of unit to ceiling. Refer to page 15 to see instructions on how to install the end flanges to the unit.

### ⚠ CAUTION

Remove the batten retainer prior to activating the unit. Failure to do so will cause damage to the screen material. Note: **Failure to comply with the instructions and guidance contained in this manual may result in voiding your warranty.**

## PREPARING THE INSTALLATION (CONTINUED)

---

The following three mounts are all available options when ordering your screen. The option that you ordered will be included in the Cascade box. Refer to the correct mount below, on how to install your Cascade unit.



Figure 2. Ceiling Mount

### Ceiling Mount

If you selected Ceiling Mount, then you will receive two ceiling mounts that can be mounted to the top of the cascade unit's top rail. Each mount has two holes pre-drilled to ensure that the unit is securely mounted at each corner (see Figure 2).

### Threaded Rod Mount

If you selected the Threaded Rod Mount, then you will receive two threaded rod mounts that can be mounted to the top of the cascade unit's rail. Each mount has two holes pre-drilled to accommodate threaded rods so that your cascade unit can be suspended from a ceiling (see Figure 3). Note: The threaded rods, themselves, are not included.



Figure 3. Threaded Rod Mount

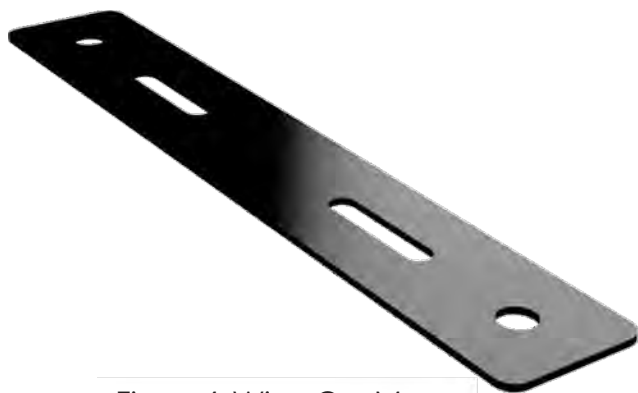

Figure 4. Wing-Out Mount

### Wing-Out Mount

If you selected Wing-Out Mount, then you will receive two wing-out mounts that can be mounted to the top of the cascade unit's rail. Each mount has two holes pre-drilled to accommodate mounting from the front and rear of the cascade unit, when viewed from audience front. This mount allows to “float” the unit left and right to accommodate ceilings with fewer ceiling joists (see Figure 4).



# CEILING MOUNT

Professional mounting techniques should be used. Stewart Filmscreen cannot be liable for substandard or faulty installations.

## ⚠CAUTION

During installation, do not place the unit on an unstable cart, stand, table or ladder. The unit may fall, causing injury to you or others as well as cause possible damage to the unit.

Do not mount to drywall only. There must be wood joists behind the drywall to secure the screen.

1. Use a magnetic stud finder, or similar appropriate means, to identify the location of solid ceiling joists. If the joists or rafters are parallel to the screen case, blocking is required between structural elements.
2. Ensure Ceiling Mount is installed on the top rail of the Cascade unit (see Figure 5).
3. Mounting hardware must be mounted into solid wood. If no joists are available then the ceiling must be blocked.
4. Lift the case up to the ceiling and screw the Ceiling Mount into the joists on both ends of the case (see Figure 6).
5. Ensure that all four mounting holes are being utilized to maximize mounting strength.
6. For the minimum clearance dimensions for Ceiling Mount, (see Figure 7).

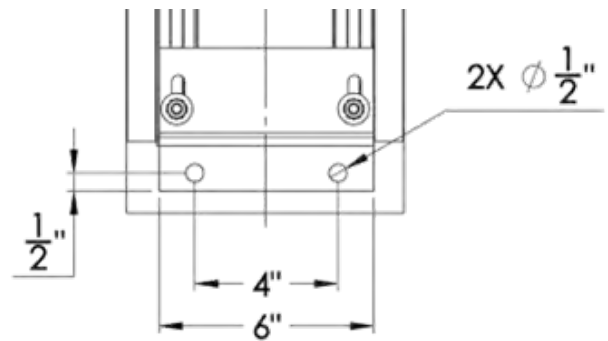

Figure 5. Ceiling Mount on top of Cascade unit

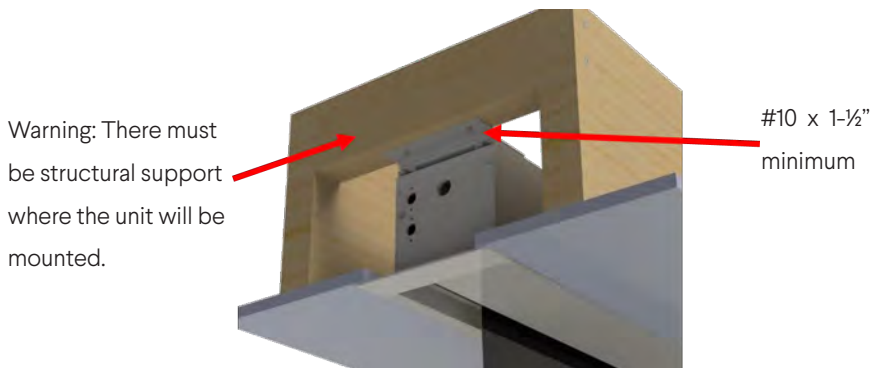

Figure 6. Cascade mounted to ceiling joists with Ceiling Mount

# CEILING MOUNT (CONTINUED)

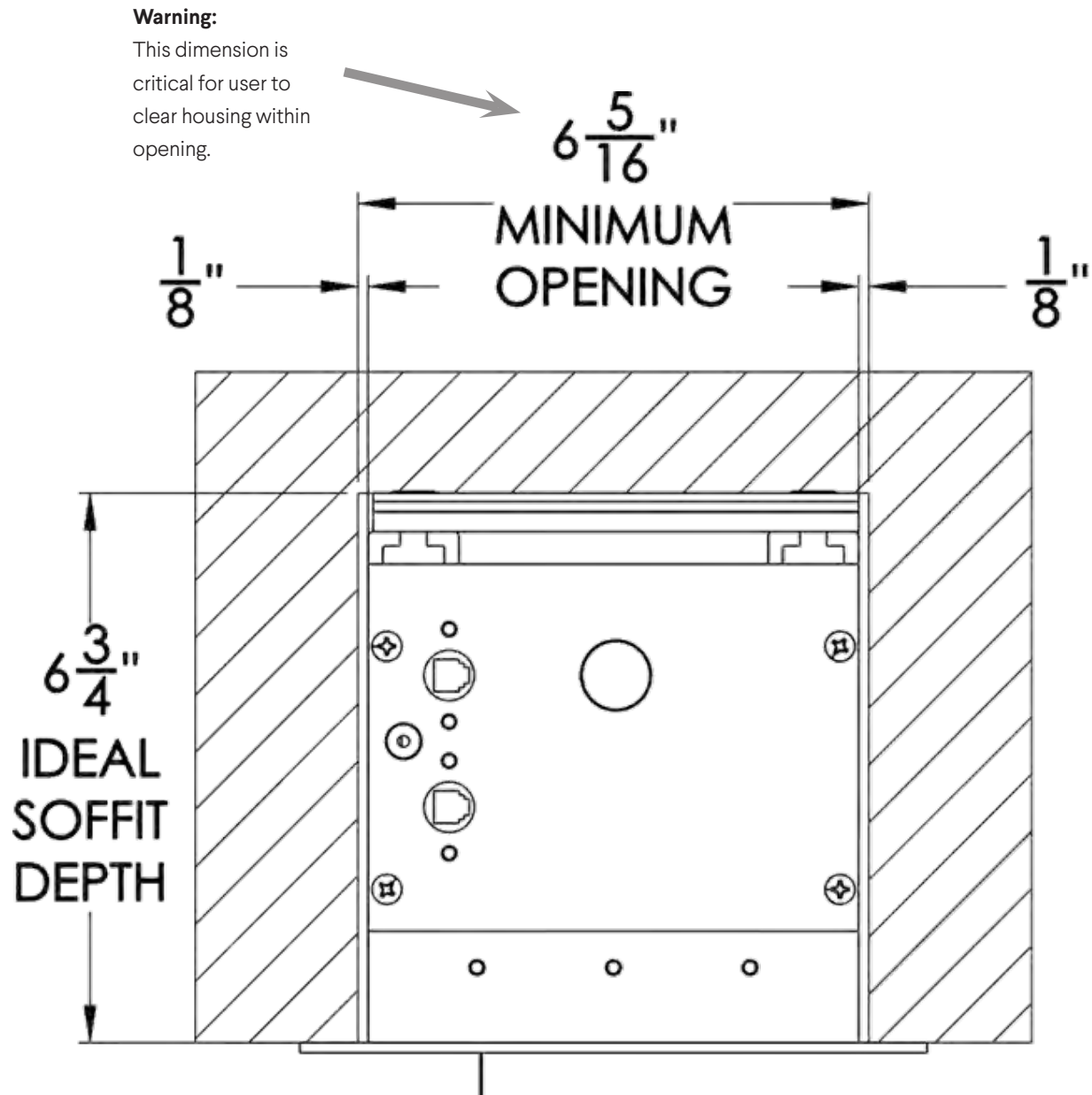

Figure 7. Ceiling Mount detail with minimum clearance

# THREADED ROD MOUNT

Professional mounting techniques should be used. Stewart Filmscreen cannot be liable for substandard or faulty installations.

## ⚠ CAUTION

During installation, do not place the unit on an unstable cart, stand, table or ladder. The unit may fall, causing injury to you or others as well as cause possible damage to the unit.

Do not mount to drywall only. There must be wood joists behind the drywall to secure the screen.

1. Raise the screen into the ceiling.
2. Fasten the mounting brackets to the threaded rods or beams above the ceiling (see Figure 7).

**Note: The unit is typically suspended, as shown in figure 8, but it can be secured to the ceiling using bolts or other appropriate fasteners as well.**

3. Mounting hardware must be mounted into solid wood. If no joists are available then the ceiling must be blocked.
4. Make sure the case is level by adjusting the threaded rod fasteners.
5. Make sure the bottom is flush with the finished ceiling.

The threaded rods, themselves, are not supplied by Stewart Filmscreen.



Figure 7. Threaded Rod Mount on top of Cascade unit

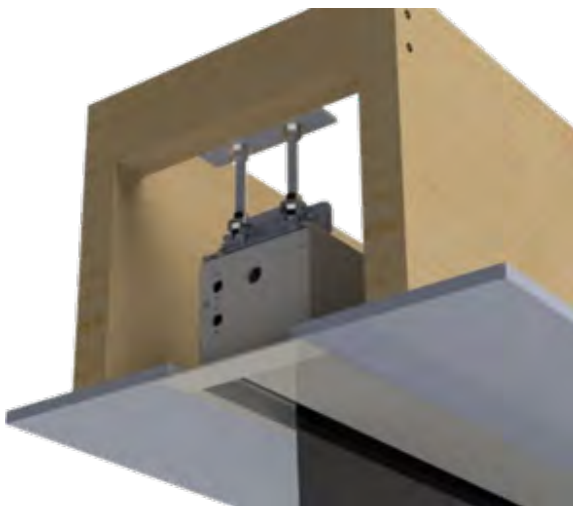

Figure 8. Cascade mounted on ceiling with Threaded Rod Mount

6. For the minimum clearance dimensions for Threaded Rod Mount, (see Figure 9).

# THREADED ROD MOUNT (CONTINUED)

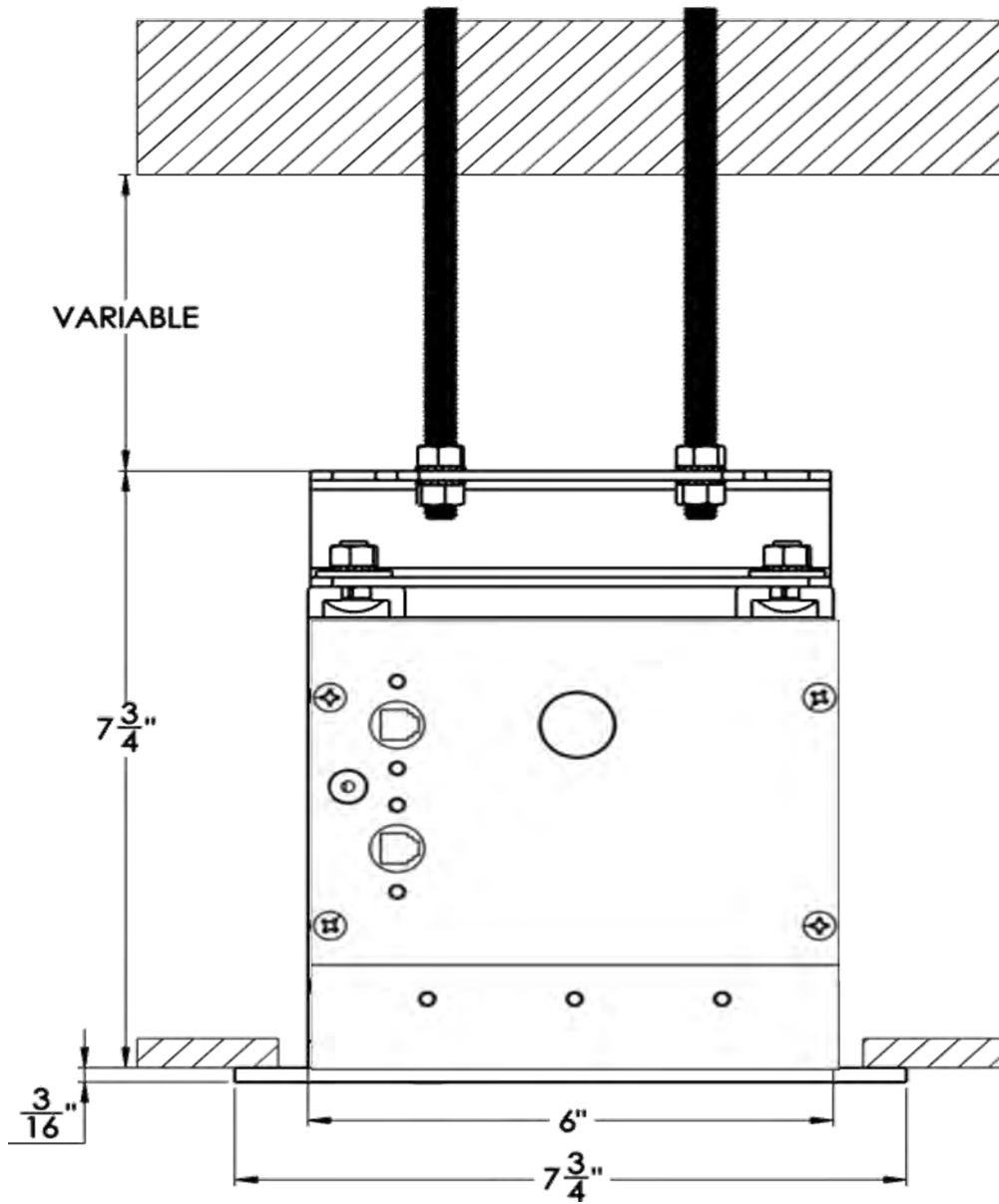

Figure 9. Threaded Rod Mount detail with minimum clearance

## WING-OUT MOUNT

Professional mounting techniques should be used. Stewart Filmscreen cannot be liable for substandard or faulty installations.

### **⚠ CAUTION**

Be careful not to touch or scratch the viewing surface.

Ensure wall surface is level and free of undulations. Use shimming if necessary.

The Wing-Out Mount is best used in applications when ceiling joists are parallel to the screen. This allows the case to be mounted on front and rear ceiling joists (see Figure 10).

1. Raise screen into the ceiling.
2. Mounting hardware must be mounted into solid wood. If no joists are available then the ceiling must be blocked.
3. Lift the case up to the ceiling and screw the Wing-Out Mount into the joists on both sides of the case (see Figure 11).
4. Ensure that all four mounting holes are being utilized to maximize mounting strength.
5. For the minimum clearance dimensions for Wing-Out Mount, (see Figure 12).



Figure 10. Wing-Out Mount installed on top of Cascade unit



Figure 11. Wing-Out Mount installed on beams that are parallel to Cascade unit

# WING-OUT MOUNT (CONTINUED)

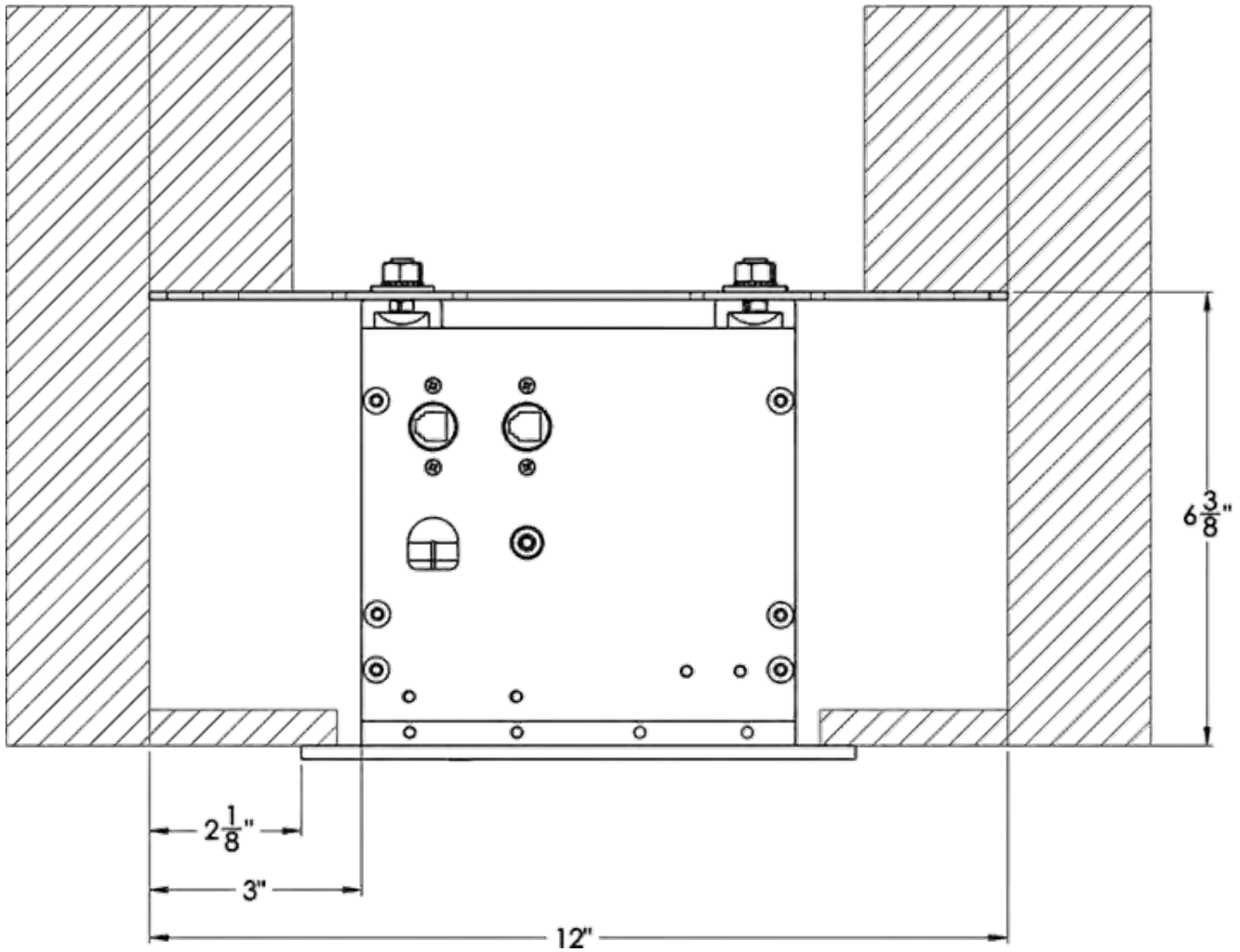

Figure 12. Wing-Out Mount detail with minimum clearance

# FASCIA END PIECE AND DUSTCOVER INSTALLATION

Cascade G2 now offers a modular construction that allows the end flange to come off for an easier installation. This greatly improves installation fit and finish while also improving the ability to access mounting points in the future. To install the end flange:

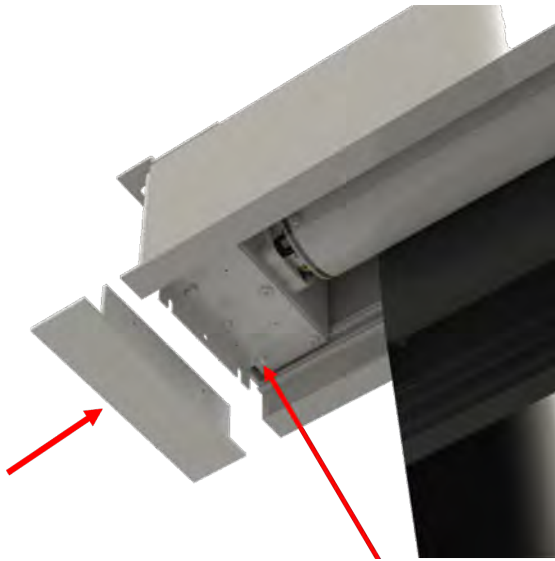

Figure 13: Render of Cascade G2 with end flange being installed.

## Fascia End Pieces

The end flanges on Cascade G2 are to be installed after the unit has been mounted, to hide access to the mounting holes in the situation that you are mounting with ceiling mounts. Three simple Phillips screws are screwed in, from the inside before you install the dust cover

## Dust Cover

Cascade G2 has a modular design in that it allows you to build out the casing with minimum amount of fasteners. In the case for the dustcover, it requires no fasteners and can be easily installed by lifting and hooking the metal extrusion onto the main body. This allows for an ease of serviceability with an unobstructed view of the internal workings from below.



Figure 14: Render of Cascade G2 with end flange installed and dust cover being installed.

# ELECTRICAL

---

The Cascade G2 screen system can be controlled through several remote control devices (IR, keypads, dry contact outputs, internet protocol (IP), and low-voltage trigger outputs).

## **⚠ CAUTION**

Cascade G2 is to be installed and used within the scope of the appropriate electrical codes and regulations. Failure to do so may cause malfunctioning or damage to the screen.

**Note:** This manual refers to AC (electrical alternating current) to represent electrical power. Your location may use 120 V, 220 V, or other electrical power. Screen systems are manufactured using the electrical power type specified for the location. Use appropriate power sources for your location.

## **MOTOR WIRING**

The Cascade G2 screen system's motor is prewired at the factory. No additional motor wiring is required.

The following pages will outline standard and optional control types for Cascade G2

## **⚠ CAUTION**

Cascade G2 has two female RJ45 inputs on audience left of case. Neither port is to be used with POE (power over Ethernet). Improper use of ports will cause irreversible damage to IMC control board and may void your warranty

## **CONNECTIONS**

The following Stewart Filmscreen accessories, plug into the RJ45 smart port.

- IR receiver (requires an RJ25 splitter)
- IR wall switch
- E-Node Internet Protocol (IP) adaptor (optional)



# INTELLIGENT MOTOR CONTROL (IMC) (STANDARD)

The IMC is a low voltage screen control that allows for switching conductors to be run in Class II (small wire, exposed, no conduit) and will interface with outboard video switching systems.

The IMC has the capability of being operated through a wall switch, infrared remote, internet protocol (IP), with (optional e-Node) control system, and a screen trigger through a projector. The IMC is the most robust controller offered for Cascade G2. For a detailed look at what the IMC has on board, please see below (see Figure 26).

The IMC comes prewired from the factory to the motor and to the power cable. For your reference, in the case of servicing, we broke down the pin layout for the high voltage side of the connections (see Figure 27). Always have a qualified electrician handle high voltage connections.

AC load side	IMC 100	Motor Power Connectors
BLACK	Pin 1	AC Line
WHITE	Pin 2	AC Neutral
	Pin 3	Motor RED Line
	Pin 4	Motor BLACK Line
	Pin 5	Motor Neutral

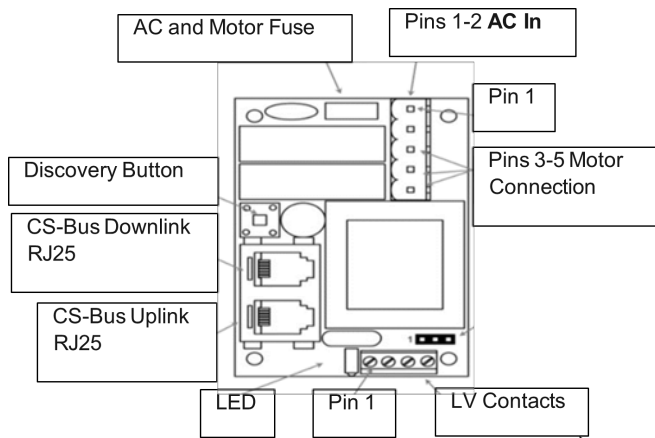

Figure 29. IMC control board schematic

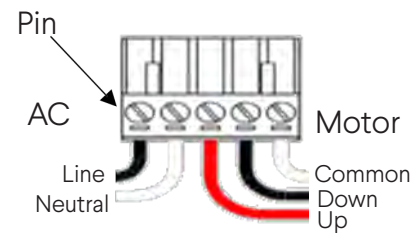

Figure 30. High voltage pin schematic

LVC Contacts	IMC 100	COMMANDS
COMMON	Pin 1	COMMON
CHANNEL 1 INPUT	Pin 2	UP
CHANNEL 2 INPUT	Pin 3	DOWN
SCREEN TRIGGER INPUT	Pin 4	TRIGGER 3-15 VDC w/ COMMON

# IMC WIRING WITH DECORA WALL SWITCH (STANDARD)

The IMC can be wired to any dry contact wall switch (see Figure 28). If you would like one from Stewart Filmscreen, you may order as an option, directly from us.

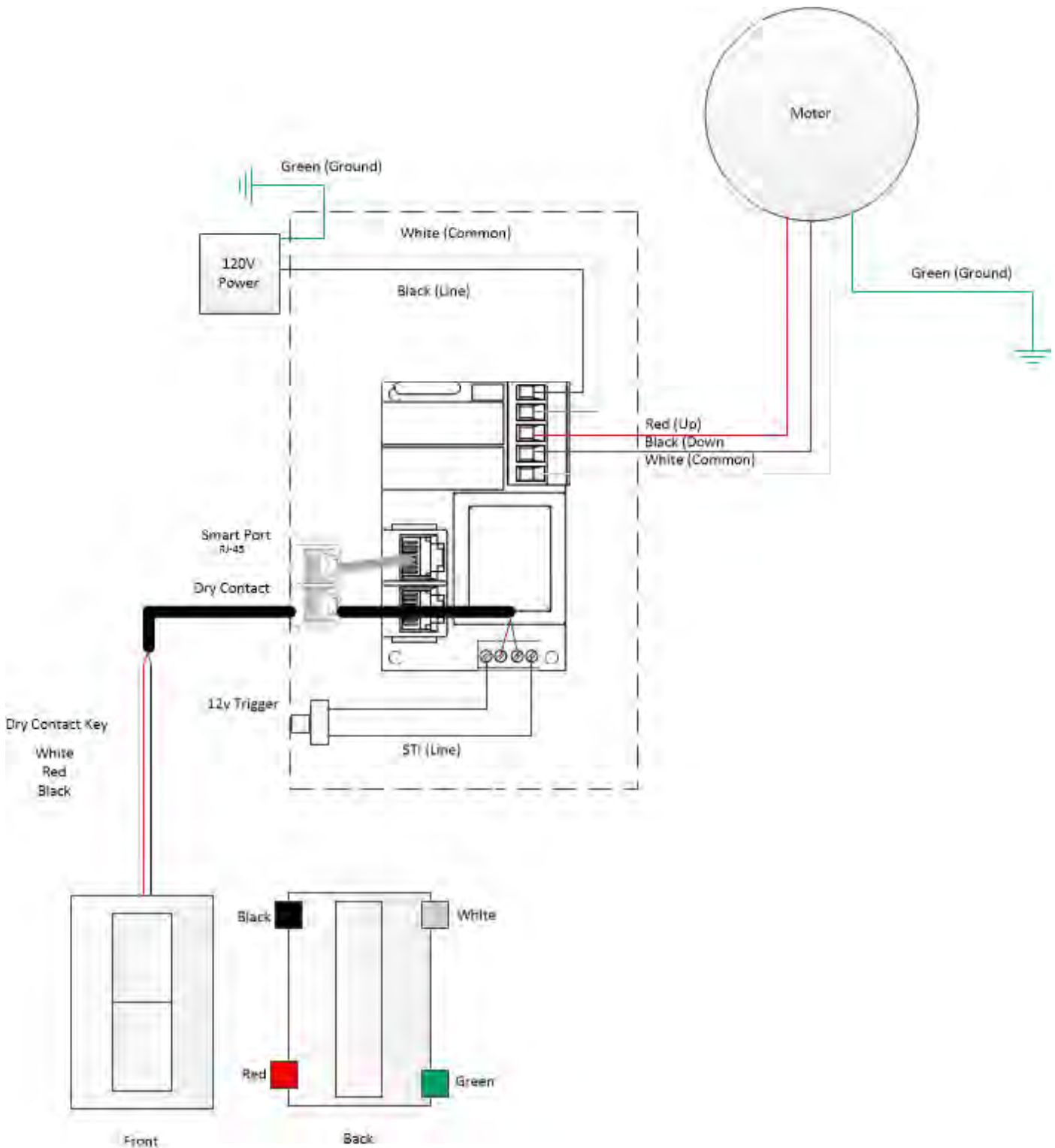

Figure 28. IMC wiring diagram

## 12 VOLT PROJECTOR TRIGGER (STANDARD)

---

Two male, mono, 3.5mm auxiliary plugs are supplied so they can be used with the standard 12 volt projector trigger feature of the IMC. Since Stewart Filmscreen cannot be certain how long of a cable will be needed for every single application, the trigger cable will have to be assembled by the installer.

### GETTING STARTED

Making the Connections

### PROJECTOR TRIGGER

1. Connect the straight, male, 3.5 mm (see Figure 15) projector trigger cable to the projector. Two male pieces, straight, and 90 degrees will be supplied for the installer to make a cable.
2. Connect the 90 degree, male, 3.5 mm (see Figure 16) trigger cable to the Cascade G2 unit's female 3.5 mm aux trigger port (see Figure 23).
3. Make sure to properly set up your projector to send a trigger signal. (Some projectors require action steps within the on-screen menu to activate trigger functionality. Please refer to your projector's owner's manual for more information.) The screen should automatically roll down and roll up when the projector is powered on and powered off.



Figure 15. Straight 3.5mm mono plug

### HOW IT WORKS

When a trigger signal is applied or removed (typically from a projector), the screen will deploy or retract accordingly. When voltage is applied (+12vdc), the screen will deploy. When the voltage signal is terminated, the screen will retract. The required trigger cable is a 2-conductor-22AWG. Many technicians use dual pairs or Cat 5 wire for this purpose.



Figure 16. 90 degree 3.5mm mono plug

## DECORA PADDLE WALL SWITCH (STANDARD)

A three position momentary wall switch (see Figure 17) can be equipped with the standard IMC control. The IMC control board comes ready to operate via the Decora paddle wall switch, right out of the box. This switch will be connected to low voltage only. **Do not connect to high voltage.**

### GETTING STARTED

#### Making the Connections

1. Connect the RJ45/RJ25 cable to the motor side endplate of the Cascade G2 case on the dry contact RJ45 port (see Figure 23).
2. Cut the other end of the wire and expose the four conductors.
3. Connect your wires to the Decora wall switch (see Figure 18).
4. For RJ45 pinouts (see Figure 28).

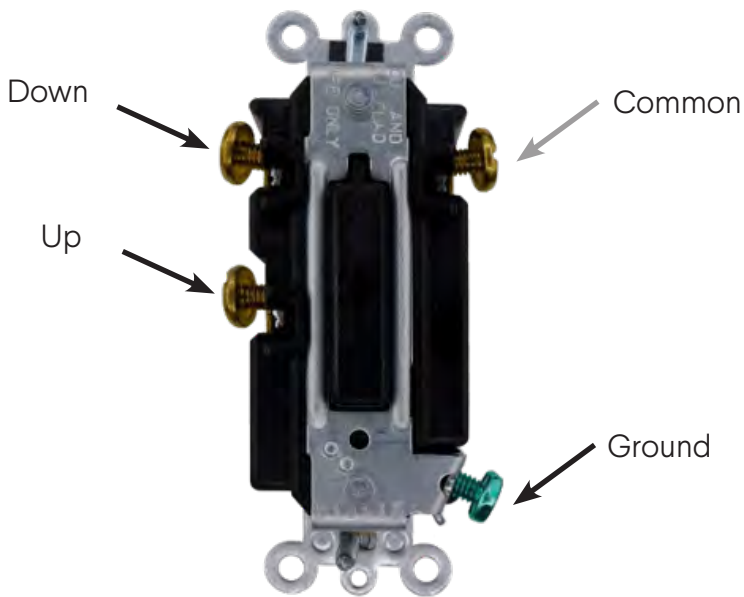

Figure 18. Rear of Decora wall switch



Figure 17. Front of Decora wall switch

### ⚠ CAUTION

Decora wall switch is to be wired through the dry contact port only. The dry contact port is low voltage. **Do not wire the wall switch through a high voltage line.**

## THREE BUTTON WALL SWITCH (IF EQUIPPED)

A three-button wall switch is supplied with your Cascade G2 unit as part of the optional control system (see Figure 19). The onboard control system comes ready to operate via the wall switch and projector trigger.

### GETTING STARTED

Making the Connections

#### 3-BUTTON KEYPAD

1. Install the wall switch anywhere in the room that is most convenient to operate the screen.
2. Connect the wall switch cable with the RJ45 end to the motor side back of Cascade G2 case on the RJ45 port (see Figure 23).
3. Connect the RJ25 cable end to the back of the three-button wall switch (see Figure 20).

**Note:** Cascade G2 comes with two RJ45 female ports. The maximum length of the RJ45/RJ25 cable plugged into the unit on the port shall not exceed 75 feet.

#### USING THE RJ25 SPLITTER

If you intend to use both the 3-button keypad and the 12v screen trigger you will need to use the included RJ25 splitter.

1. First, using the short RJ45/RJ25 cable attach the RJ45 end to the back of the screen's RJ45 port.
2. Connect the RJ25 splitter to the RJ25 end of the cable.
3. You will need to make an RJ25/RJ25 cable to connect the keypad to the splitter.



Figure 19. Front of wall switch



Figure 20. Rear of wall switch with RJ25 input

**Note:** See the section, "Limit Switch Adjustment" (see Page 25), for information regarding the default limits to which the screen can be adjusted up or down from the factory preset.

# IMC WITH IR RECEIVER AND REMOTE (IF EQUIPPED)

A 3-button IR (infrared) remote control (see Figure 21) is supplied for the IMC (see Figure 22). The IMC control board comes ready to be operated via IR and projector trigger, right out of the box. You may visit [support.stewartfilmscreen.com](http://support.stewartfilmscreen.com) for a full list of IR Hex codes if you want to program the IR to another remote.



Figure 21. IR remote



Figure 22. IMC control board

## GETTING STARTED

### Making the Connections

1. Connect the IR eye with RJ25 end to the motor side endplate of Cascade on the smart port with RJ45 as shown (see Figure 19).
2. Place the IR eye anywhere in the room, making sure that there are no obstructions between the eye and the screen.

**Note:** Cascade comes with two RJ45 female inputs. The maximum length of the RJ45/RJ25 cable plugged into the unit shall not exceed 75'. Dry closure modules from any home automation system can be interfaced, utilizing up/down/common type terminations only on the dry contact port and maximum length of cable shall not exceed 250'.

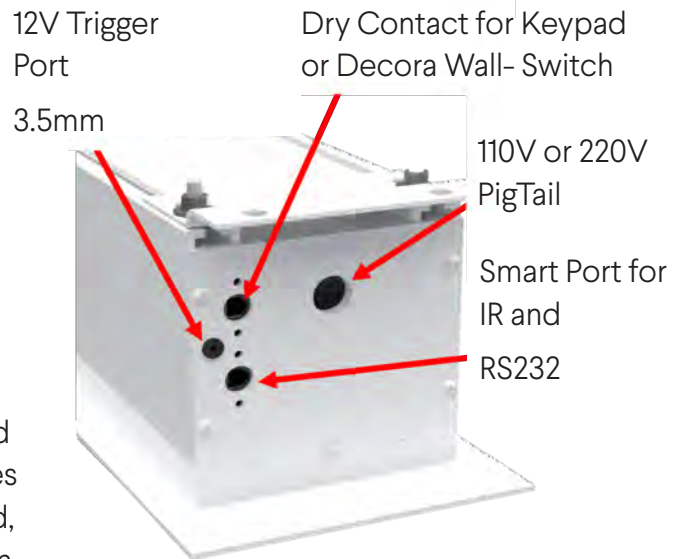

Figure 23. Audience left of case with power pig tail port, two RJ45 ports and a 3.5 mm trigger port

## IR WALL SWITCH AND REMOTE (IF EQUIPPED)

A 3-button IR (infrared) remote control (see Figure 21) is supplied in conjunction with the 3 button IR (infrared) wall switch (see Figure 23) for the IMC (see Figure 22). The IMC control board comes ready to operate via the IR and projector trigger, right out of the box. You may visit [StewartFilmscreen.com](http://StewartFilmscreen.com) for a full list of IR Hex codes if you want to program the IR to another remote. Instead of receiving an IR receiver eye, you will receive a wall switch with the eye built in.

### GETTING STARTED

#### Making the Connections

1. Connect the RJ25 cable to the back of the IR wall switch (see Figure 24).
2. Connect the IR wall switch cable with RJ45 end to the motor side endplate of Cascade G2 on the smart port with RJ45 as shown (see Figure 23).
3. Install the IR wall switch anywhere in the room, making sure that there are no obstructions between the eye and the screen.
4. Keep note that you may want to hide the cable inside your wall to ensure a clean install.



Figure 23. Front of IR wall switch

**Note:** Cascade G2 comes with an RJ45 female smart port. The maximum length of the RJ45/RJ25 cable plugged into the unit on the smart port shall not exceed 75.

### OPERATION

Using the IR remote, press the “down” button and the Cascade G2 screen will automatically extend fully to its preset limit and will power itself off. Press the “up” button once and the Cascade G2 screen will automatically retract back into the case and power itself off. If a custom position is desired, simply press the “stop” button at any time during the screen’s deployment or retraction.



Figure 24. Rear of IR wall switch with RJ25 input

**Note:** See the section, “Limit Switch Adjustment” (see Page 25), for information regarding the default limits to which the screen can be adjusted up or down from the factory preset.

## OPERATING THE SCREEN

---

### NOTE

After the screen has been properly mounted, make sure that the batten retainers have all been removed. Failure to remove the batten retainers before operating the screen will cause irreparable damage to the screen's projection surface.

Using the wall switch, press the “down” button and the Cascade G2 screen will automatically extend fully to its preset limit. Press the “up” button once and the Cascade G2 screen will automatically retract back into the case and power itself off. If a custom position is desired, simply press the “stop” button at any time during the screen's deployment or retraction.

***Note: When you lower or retract the screen, it will stop at its preset limit. If an obstacle, such as a person or any furniture, is in the path of the screen as it is lowered, use the switch control to stop the screen's motion. The screen will not automatically stop if it hits an obstacle.***

The motor is designed to be used for short operations such as lowering the screen in preparation for viewing. The motor is not designed for continuous duty. If the motor operates continually for more than a few minutes, it may automatically shut off to prevent damage from overheating. If the motor occasionally needs to be run more than normal, i.e., during initial setup and positioning, allow time for the motor to cool down.

In general, when the screen is not in use, you should store it in the fully retracted position to protect the screen's surface. **It is best practice however, to deploy the screen for extended periods. Periodic deployment on a regular basis will maximize the flatness and uniformity of the screen's surface. The screen will benefit from frequent and extended periods of deployment.**

### ⚠ CAUTION

Be careful not to touch or scratch the screen's viewing surface.

### ⚠ CAUTION

If the unit emits any smoke, heat, abnormal noise or unusual odor, the unit is most likely damaged in some way — such as damage from a water leak or power surge. Do not operate the motor if any of these situations occur. Call a qualified service person for assistance.



# ADJUSTING THE SCREEN LIMIT SWITCH

---

## **⚠ CAUTION**

Improper adjustment of the limit switches can cause irreparable damage to the screen itself, resulting in voiding the factory warranty. Adjust these switches by hand only. **Never use a power tool as motor will result.**

## **DESCRIPTION**

The extension and retraction limit switches have been preset at the factory. In general, we advise you to avoid readjusting these switches. In some cases, to enable proper alignment of the displayed image on the screen, you may need to adjust the extension of the screen. If adjustment to the extension is necessary, carefully follow these instructions.

## **WARNING!**

The screen is fully retracted when the batten is flush with the bottom of the case. Do not attempt adjustments with the yellow retraction (UP) limit switch that will further retract the screen. Incorrect adjustment of the switch will cause severe screen damage. Please consult the factory if you have any questions.

## **ADJUSTING THE SCREEN EXTENSION**

You can increase the extension of the screen up to 3" (7.6 cm) past the factory preset stop, or you can decrease the extension by approximately 4-6" (10 - 15 cm) from the factory preset stop. Do not attempt to modify the screen extension beyond these recommended amounts.

The limit switches are located on the left side (audience left) of the screen roller tube inside the case, after removing the dust cover.

To increase the screen's fully extended (screen down) stop position:

1. Lower the screen to its current stop position.
2. Remove the dust cover to locate the white extension (down) limit switch on the left side of the screen tube (audience left). Use a small electrician's style screwdriver or a 5/32" (.4 cm) hex wrench to turn the switch in a counterclockwise direction. If the power is still on, the screen will drop incrementally as the switch is turned.

**Note:** One complete turn of the switch will make approximately a 3/4" (2 cm) change in the screen's stop position.

## LIMIT SWITCH ADJUSTMENT (CONTINUED)

### ADJUST THE SCREEN'S RETRACTED (UP) STOPPING POSITION

**CAUTION:** Making adjustments to the yellow switch can inadvertently damage the screen or the motor if the fully retracted stopping position is set too high into the housing. This will cause the screen's batten bar to impact the screen roll and may cause optical damage to the screen. Improper adjustment can also cause the batten to jam into the housing which obstructs it from deploying when the "down" command is sent. Left in this position, the motor will fail due to overrun. Only qualified, experienced technicians should attempt to make adjustments to the "up" yellow limit switch (see Figure 25).

**NOTE: Failure to follow these directions may result in voiding your warranty.**

In the fully "up" retracted stopping position, the screen's batten bar must hang freely underneath the screen roller tube. **The batten bar cannot contact or press against the projection screen roll.**

**Make sure to check and correctly adjust the yellow or "up" limit switch to avoid screen damage from a compacted batten bar.** Switches are sensitive. Go slowly and do quarter turns at all times with the 5/32" hex driver to prevent damage to the motor and to the screen.

Counterclockwise adjustments of this switch will raise the batten bar and clockwise adjustments will lower the batten's top setting. Lowering the batten's top stopping position is valuable when trying to align the screen's batten with the bottom of the Cascade G2 case.

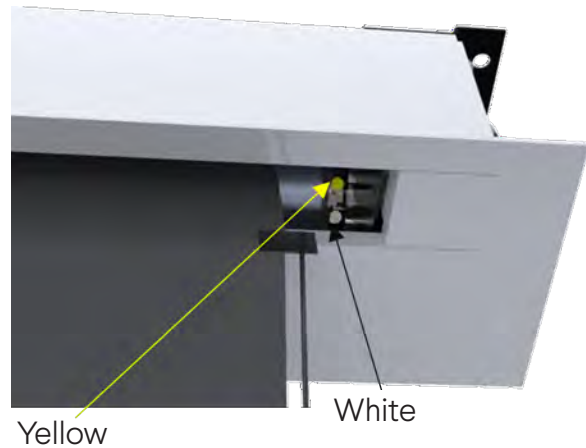

Figure 25. Undercarriage, back view, audience left side of Cascade G2. Motor with yellow and white adjustment limits

#### **⚠ CAUTION**

Please remember that improperly adjusted motor limit switches will cause damage to your projection screen or motor. Make sure that both of the motor limit switches have been properly adjusted, allowing the projection screen to stop correctly at both the retracted and deployed positions.

## CARING FOR AND CLEANING THE SCREEN

---

With reasonable care, you may expect many years of dependable use of your Stewart projection screen. We encourage you to keep your screen clean. To protect your screen when it is not in use, store it in the fully retracted position.

Avoid getting any foreign material on the screen, as cleaning may prove very difficult. It may not be possible to remove scratches, paint, ink, etc.

### **GENERAL MAINTENANCE**

Treat your screen surface delicately. Special attention to these instructions should be followed when cleaning.

- ▶ A draftsman-style brush may be used to lightly whisk away any loose dirt or dust particles. (This type of brush is usually available at office supply stores.) Stewart Filmscreen has an optional screen cleaning kit that contains the proper type of brush. Contact your dealer if you would like to obtain this cleaning kit.
- ▶ Particles left on the screen when it is retracted into the case may form an impression on the screen surface. Periodically wipe the back of the screen with a clean damp cloth.
- ▶ For tougher spots, you can make a cleaning solution using a water-based detergent and warm water. To make the solution, mix one part Simple Green, 409, or other water based industrial cleaner with three parts warm water. Moisten a clean cotton cloth or Q-Tip with this solution, moisten the stained area, and gently lift off the stain. Never use an aggressive scrubbing action as you could damage the screen surface by removing the optical coating. Remoisten the area with clean water and dab dry with a clean sponge or cotton cloth. Any residual watermarks will evaporate on their own in a few minutes.

Do not use any other cleaning materials on the screen. Contact the factory if you have questions about removing difficult spots.

### **WEEKLY MAINTENANCE**

To maximize the longevity of your Cascade G2 screen we recommend the screen be deployed overnight at least once a week. If using a 3rd party control system to deploy your Cascade G2 screen, you may be able to program the 3rd party system to automatically deploy your Cascade G2 screen once a week.

### **REPLACEMENT PARTS & SERVICE**

No user-serviceable parts are contained within the unit. Contact your dealer or the factory if you require part replacement or service.

# TROUBLESHOOTING

Refer to the following guidelines if you encounter a difficulty in the operation of your Stewart Filmscreen product. Problems related to electrical or motor function may require a qualified service person or electrician. Should you have a problem that is not addressed here, call Stewart Filmscreen Corporation (310-784-5300) Toll free (800-762-4999). E-Mail: techsupport@stewartfilmscreen.com

Problem	Cause	Action Steps
Screen won't operate.	No AC power available.	Check to see if the circuit breaker has switched off. Reset if needed. Check outboard switching apparatus. Check voltage availability. Contact an electrician.
Screen won't roll up or down (even though power is available).	Bad connection at switch. Polarity of IMC / STI line may be bad.	Have an electrician or qualified service person check the connection as follows: <ul style="list-style-type: none"> <li>▶ If you have a low voltage control unit, check the switchline connections.</li> <li>▶ Check STI / IMC module's line connections or the miniplugs at the screen input or projector output.</li> </ul> Check 12V DC line for correct polarity. Contacts may be sticking- tap relay to free contacts.
Screen roller chatters when power is activated.	Can be caused by voltage drop, bad connections, or a defective switch.	Have an electrician or qualified service person check all hookups including all outboard wiring.
Unit hums in up mode. (Screen has already retracted.)	The screen batten is retracting too far into the case. Failure to correct can damage motor and screen. Do not use the unit until this problem is resolved.	Have a qualified service person adjust the yellow UP limit switch.
Screen drops when up direction is activated (grinding noise occurs).	Drop in voltage.	Screen motor requires full voltage. Have an electrician or qualified service person check available voltage.

## TROUBLESHOOTING (CONTINUED)

Problem	Cause	Action Steps
Screen continues past bottom stop position.	White limit switch is out of adjustment.	Readjust the white DOWN limit switch. See the section on Adjusting the Screen Extension of this manual.
Motor shuts off. Motor has been in use for more than 2 minutes.	Motor is designed for short operations (lowering and retracting), not continuous duty. Longer operation, causes the motor to overheat and shut off.	Allow the motor to cool down. Complete cooling can take an hour or more. Heat gain is cumulative and takes time to dissipate. If motor use is initiated before it has cooled completely, the motor will shut down again when it reaches maximum temperature.
Dirt, fingerprints, marks, etc. on screen surface.	Improper handling of screen.	Lightly brush off or use a mild detergent solution with a clean rag or cotton swab.
Indentations appear on screen surface.	Debris or particles adhering to screen due to static cling.	Check back of screen; gently brush debris away with a draftsman-style brush.

## LIMITED ONE YEAR WARRANTY

---

STEWART FILMSCREEN CORPORATION (Stewart) warrants all products to the original purchaser only. Stewart products are guaranteed to be free from defects in materials and workmanship for a period of one (1) year from the date of purchase by the original purchaser or eighteen (18) months from date of manufacture, as defined in the serial number. Additionally, all products must be properly operated and maintained according to Stewart instructions and cannot be damaged due to improper handling or treatment after shipment from the factory. This warranty does not apply to equipment showing evidence of misuse, abuse, or accidental damage, including neglect caused by improper installation (i.e. proximity to hot lights, exposure to extreme heat or cold, exposure to excessive humidity, etc.)

Stewart on-site warranty repair services are not available for this product. Stewart's sole obligation under this warranty shall be to repair or to replace (at Stewart's sole discretion) the defective part of the merchandise. This warranty expressly does not cover any costs of removal, installation, framing, or other costs incidental to replacing the screen or returning it to Stewart. Returns for service should be made to your Stewart dealer. If it is necessary for the dealer to return the screen or part to Stewart, transportation (freight) expenses to and from Stewart are payable by the purchaser. Stewart is not responsible for damage in shipment. To protect against damage or loss in transit, insure the product and prepay all transportation expenses.

This warranty is in lieu of all other warranties, expressed or implied, including warranties as to fitness for use or merchantability. Any implied warranties of fitness for use, or merchantability, that may be mandated by statute or rule of law are limited to the one (1) year warranty period. This warranty gives you specific legal rights, and you may also have other rights which vary from state to state. In no event will Stewart be liable for sums in excess of the purchase price of the product. No liability is assumed by Stewart for expenses or damages resulting from interruption in operation of equipment, or for incidental, direct, or consequential damages of any nature. In the event that there is a defect in materials or workmanship of a Stewart Filmscreen product, you may contact our Customer Service Department at 1161 W Sepulveda Blvd, Torrance, California 90502- 2797 (310-784-5300) Toll free (800-762-4999).

**IMPORTANT:** This warranty shall not be valid and Stewart shall not be bound by this warranty if the product is not operated and maintained in accordance with Stewart's written instructions. Stewart Filmscreen Corporation shall not be liable for any and all consequential damage(s) occasioned by the breach of any written or implied warranty pertaining to the sale of a Stewart Filmscreen product in excess of the purchase price of the product sold.





The Reference for Stunning™

[www.stewartfilmscreen.com](http://www.stewartfilmscreen.com)

1161 W. Sepulveda Blvd., Torrance CA 90502 USA | 800.762.4999 | Tel: 310.784.5300 | Email: [request@stewartfilmscreen.com](mailto:request@stewartfilmscreen.com)

2024© Stewart Filmscreen. Specifications are subject to change without notice.